

Pipe Jacking Association

An introduction to pipe jacking and microtunnelling

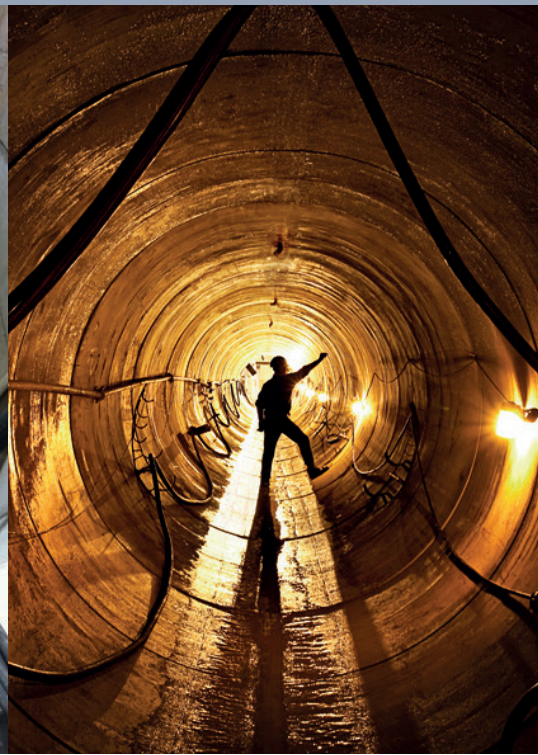

Copyright © Pipe Jacking Association

ISBN 978-1-5272-0341-9

All rights reserved. No part of this publication may be reproduced, stored in a retrieval system, or transmitted in any form or by any means, electronic, photocopy, recording or otherwise, without the prior permission of the publisher.

Whilst the Association does its best to ensure that any advice, recommendations or information it may give is accurate, no liability or responsibility of any kind (including liability for negligence) is accepted by the Association its servants or agents, in this respect.

Published by the

Pipe Jacking Association

www.pipejacking.org



Published: January 2017

Price: £25.00

Contents



1 THE PIPE JACKING TECHNIQUE

4

An overview of pipejacking and microtunnelling and its benefits

2 APPLICATIONS AND BENEFITS

8

2a) Table comparing the environmental aspects and carbon savings of open trench and pipe jacked sewer construction at two typical sewer diameters

3 SITE INVESTIGATION AND INFORMATION REQUIRED ON SOIL CONDITIONS

10

3a) Diagram showing typical ground information required for design and costing

3b) Table of parameters to be considered in relation to each soil type

3c) Table illustrating ground treatment and face support methods for varying ground conditions

4 DESIGN AND CONSTRUCTION METHODS

13

4a) Table: Design of working shafts in dry ground

4b) Table: Design of working shafts in wet ground

4c) Table of indicative jacking lengths achievable between shafts for mechanised drives

4d) Guidelines for curved drives

4e) Table illustrating pipe jacking excavation methods for dry and wet ground

5 PIPE JACKING PIPES

20

Different pipe materials and secondary linings and their uses

6 JACKING LENGTHS, LOADS AND TOLERANCES

22

1 The pipe jacking technique

Pipe jacking/microtunnelling* is a non-disruptive method of installing utility tunnels and conduits by thrusting pipes through the ground as controlled excavation is undertaken at the face. Pipes manufactured in a variety of materials to include concrete, clay, grp and steel can be jacked and standard pipe diameters generally range from 150mm to 2,400mm, or greater when required. Jacking lengths achievable can be considerably in excess of 1km depending on pipe diameters, ground conditions and excavation methods.

Drive lengths are only limited by practical engineering considerations and economics and drives either in a straight line or to a radius or a series of radii are readily achievable.

Pipe jacking can deliver environmental benefits in excess of 75% as measured by reduced carbon emissions compared to disruptive open-cut construction, which requires considerably greater amounts of excavation and substantial backfill material. Long-term damage to existing installed infrastructure is also minimised.

***Microtunnelling** - originally used to describe the construction of fully automated non man entry pipe jacked tunnels in smaller diameters, the term is now also sometimes applied to fully automated pipe jacks in larger diameters which may be controlled from above ground.

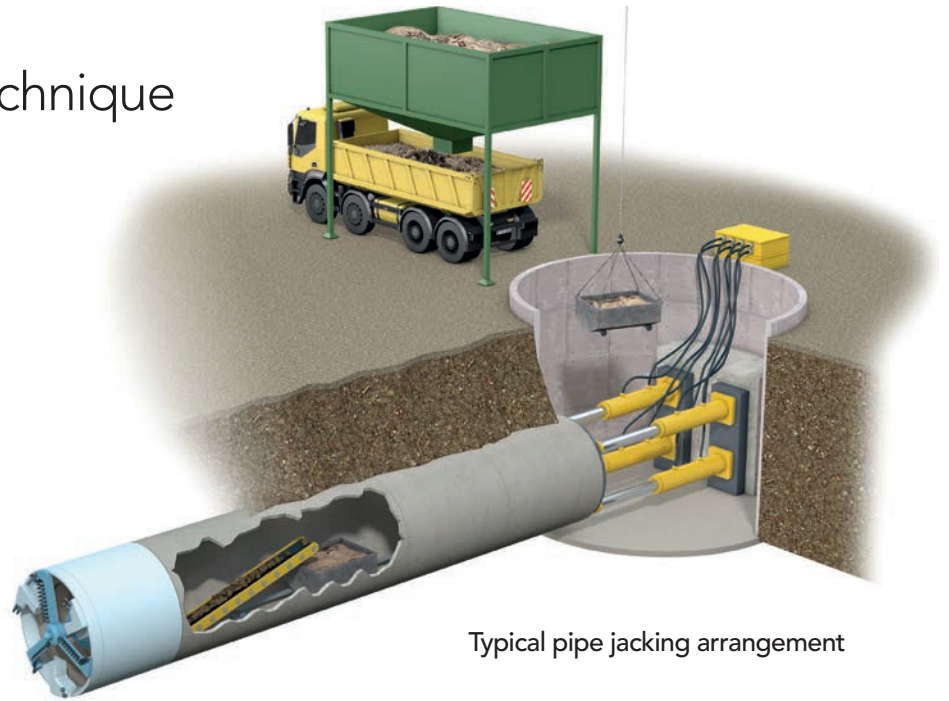

Typical pipe jacking arrangement

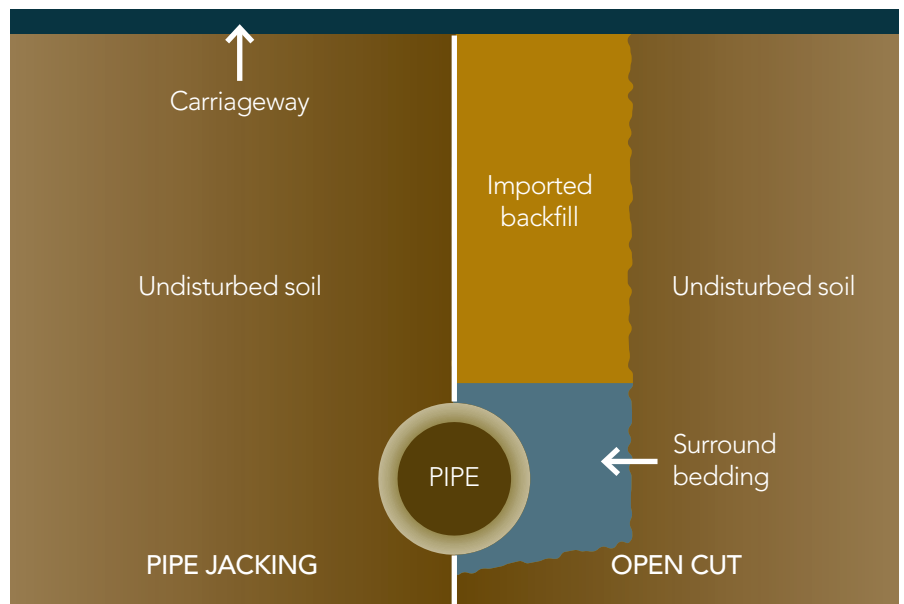

Environmental benefits - carbon emissions reduced by up to 75%



A number of types of mechanical excavation systems are available and these are similar to those employed in other forms of tunnelling. Shields, excavation and face support can be provided for a wide variety of ground conditions.

Construction tolerances are comparable with other tunnelling methods, and the pipe jacking method generally requires less overbreak than segmental tunnels and provides ground support and reduces potential ground movement.

The pipe jacking technique and its components have been subject to extensive and ongoing research at leading UK universities including both Oxford and Cambridge. This has included model and full scale testing of pipes and joints and the effects of lubrication and soil conditioning on the pipe jacking process.



TUNNEL BORING MACHINE (TBM)



CUTTER BOOM

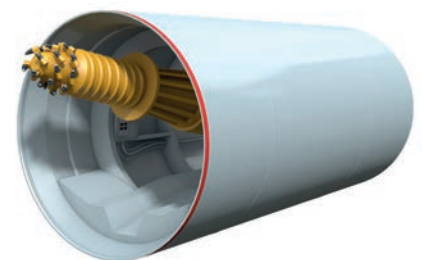

BACKACTER

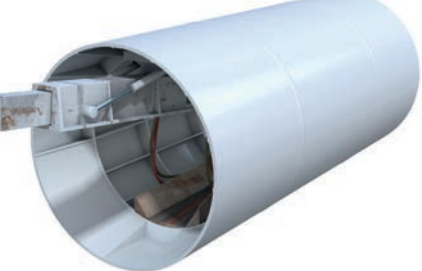

EARTH PRESSURE BALANCE (EPBM)

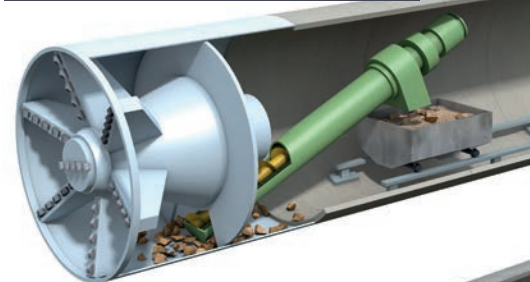

PRESSURISED SLURRY

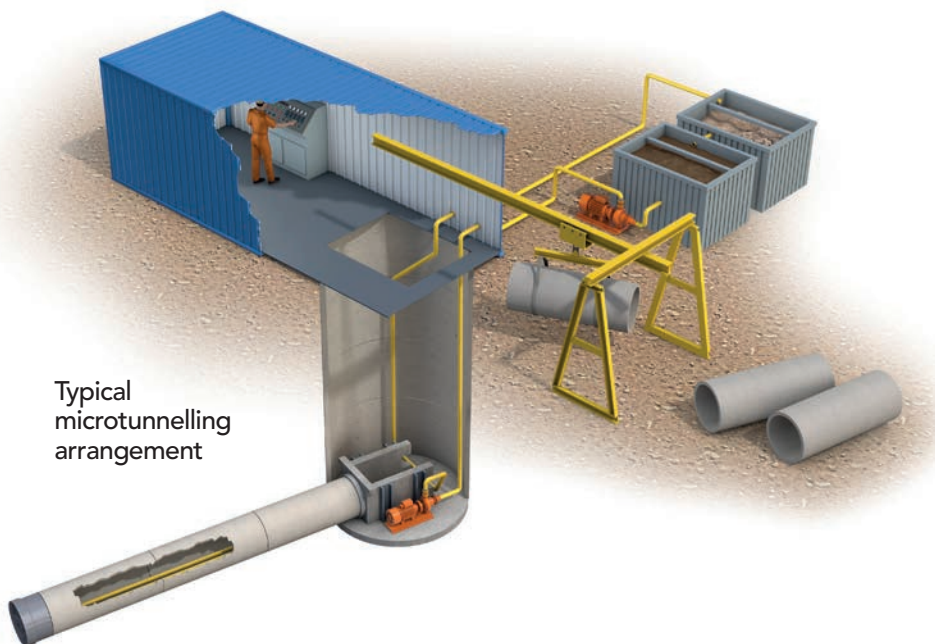
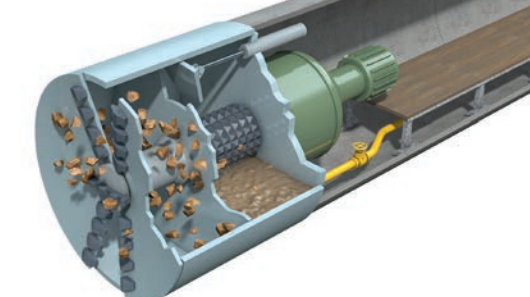

Typical microtunnelling arrangement



In order to install a pipeline using this technique, thrust and reception pits are constructed, usually at manhole positions.

The dimensions and construction of a thrust pit vary according to the specific requirements of any drive with economics being a key factor. Pit sizes will vary according to the excavation methods employed, although these can be reduced if required by special circumstances.

A thrust wall is constructed to provide a reaction against which to jack. In poor ground, piling or other special arrangements may have to be employed to increase the reaction capability of the thrust wall. Where there is insufficient depth to construct a normal thrust wall, for example through embankments, the jacking reaction has to be resisted by means of a structural framework having adequate restraint provided by means of piles, ground anchors or other such methods for transferring horizontal loads.

To ensure that the jacking forces are distributed around the circumference of a pipe being jacked, a thrust ring, mounted on the jacking rig, is used to transfer the loads. The jacks are interconnected hydraulically to ensure that the thrust from each is the same. The number of jacks used may vary because of the pipe size, the strength of the jacking pipes, the length to be installed and the anticipated frictional resistance.

A reception pit of sufficient size for removal of the jacking shield is normally required at the completed end of each drive. The initial alignment of the pipe jack is usually controlled by accurately positioning guide rails within the thrust pit on which the pipes are laid. To maintain accuracy of alignment during pipe jacking, it is necessary to use a steerable shield, which must be frequently checked for line and level from a fixed reference. For short or simple pipe jacks, these checks can be carried out using traditional surveying equipment. Rapid excavation and remote control techniques require sophisticated electronic guidance systems using a combination of lasers and screen based computer techniques.

When the pipejack or microtunnel is carried out below the water table it is usual to incorporate a headwall and seal assembly within each thrust and reception pit.

The use of these items prevents ingress of ground water and associated ground loss, and retains annular lubricant.





Thrust pit set-up

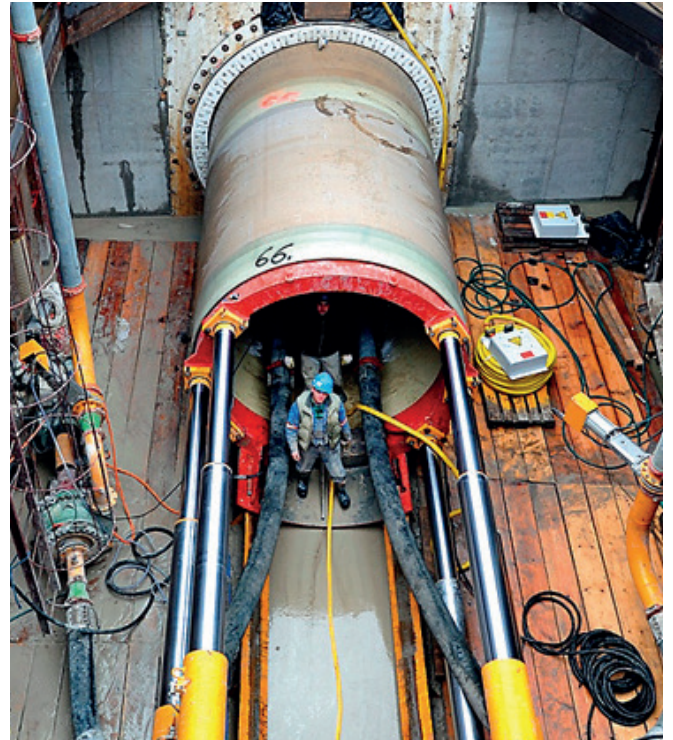

Jacks and thrust ring



Computer guidance systems for pipe jacking and microtunnelling



2 Applications and benefits



The major applications for pipe jacking and microtunnelling include new sewerage and drainage construction, sewer replacement and lining, gas and water mains, oil pipelines, electricity and telecommunications' cable installation, and culverts. Special applications include the installation of rectangular or circular sections for pedestrian subways, road underpasses and bridge abutments.



The technique can be used to negotiate obstacles such as motorways, railways, rivers, canals, buildings and airfields in the path of pipe laying projects; to minimise the surface disruption frequently associated with open cut pipe laying methods in urban areas; or simply to provide a permanent underground tunnel construction.



Pipe jacking is primarily used as an alternative to open cut excavations or other tunnelling methods. Significant lengths are attainable at larger diameters using mechanised techniques. Reference should be made to Tables 4c and 4d for specific recommendations.

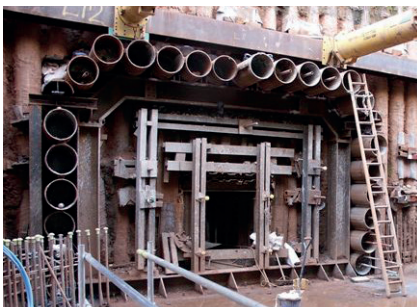

Construction methods are available to cope with both cohesive and non-cohesive soils in dry or water bearing conditions. Excavation techniques are also available for jacking through rock or mixed ground conditions, including cobbles and boulders.

TECHNICAL BENEFITS

Technical benefits associated with pipe jacking are:

- Inherent strength of lining
- Smooth internal finish giving good flow characteristics
- No requirement for secondary lining
- Speed of installation
- Considerably less joints than a segmental tunnel
- Prevention of ground water ingress by use of pipes with sealed flexible joints
- Provision of invert channels in larger pipes to contain the dry weather flow of a sewer in a combined system
- Less risk of settlement
- Minimal surface disruption
- Minimal reinstatement
- Reduced requirement for utilities diversions in urban areas

ENVIRONMENTAL BENEFITS

There are substantial environmental benefits to be gained by the use of pipe jacking techniques when compared with the traditional open trench approach. Typically the 'trenchless' method will reduce the quantities of incoming and outgoing materials, with a consequent reduction in tipping of spoil and quarrying of imported stone fill. This in turn leads to reduced vehicle movements and subsequently less associated disruption.

The table below compares the environmental aspects of open trench and pipe jacked sewer construction at two typical sewer diameters. The comparison assumes that excavated spoil is removed from site to a licensed tip, and that any resultant void after the pipe has been installed is replaced by imported stone backfill overlain by a coated stone surface reinstatement.

2a) Comparing the environmental aspects and carbon savings of open trench and pipe jacked sewer construction at two typical sewer diameters

| Aspect | 600mm ID pipeline 4m deep, 100m length | | 1200mm ID pipeline 4m deep, 100m length | |
|---|---|-------------------------------|--|--------------------------------|
| | Open trench | Trenchless | Open trench | Trenchless |
| Excavated width | 1400mm (trench width) | 760mm (OD of jacking pipe) | 2350mm (trench width) | 1450mm (OD of jacking pipe) |
| Reinstatement width | 1700mm | None | 2650mm | None |
| Excavated volume per metre of pipeline | 6.1m ³ | 0.5m ³ | 10.28m ³ | 1.65m ³ |
| Imported stone fill and coated stone per metre of pipeline | 11.9 tonnes | None | 18.27 tonnes | None |
| Number of 20 tonne lorry loads per 100m pipeline (muck away and imported stone) | 136 | 8 | 220 | 21 |
| Tonnes CO ₂ emissions | 66.7 | 27.1 | 110.6 | 69.7 |

SAFETY BENEFITS

Pipe jacking is an inherently safer method of working than open trench construction or traditional segmental tunnelling. When considering the risks associated with deep, large section, open excavations, Health and Safety Executive guidance suggests these risks should be reduced "if appropriate using 'trenchless' technology to avoid the need to excavate the trench in the first place". Given gang size differences between the techniques and the resulting reduction in man-hours, the incidence of accidents are less with pipe jacking. There is also significant reduction in the risk of injury as a result of utility strikes and interface with the public.

Since manholes and the delivery of pipeline materials are common to both construction methods, for comparison their environmental effects can be ignored.

As a result of the foregoing the carbon impact is significantly reduced, particularly on urban main drainage and flood relief schemes and this can be readily assessed using the carbon calculator on the PJA website. This carbon calculator was developed by the Transport Research Laboratory and verified by the Water Research Centre.

In many cases the use of pipe jacking techniques instead of open trenching will contribute positively towards workplace safety, the interface with the general public, and the local and wider environment.

3 Site investigation and information required on soil conditions

SITE INVESTIGATION: GENERAL

When designing and costing works to be carried out by pipe jacking, a thorough site investigation, both factual and interpretative, and report is required in order to determine the characteristics of the soils likely to be encountered, together with details of the water table in the vicinity.

The site investigation should follow the guidance given in:

- Eurocode 7: Geotechnical design - Part 1: General rules and Eurocode 7: Geotechnical design - Part 2: Ground investigation and testing
- UK Specification for Ground Information (ICE Site Investigation Steering Group)
- BTS Tunnel Lining Design Guide, Chapter 3, Geotechnical characterisation
- All exploratory hole work, associated sampling, in situ testing and logging shall be carried out in accordance with techniques outlined in BS 5930:2015, BS EN ISO 14689-1:2003, BS EN ISO 14688-1:2002, BS1377:1990 and BS EN ISO 22476/3: 2005 as appropriate.
- Closed-Face Tunnelling Machines and Ground Stability, produced by the British Tunnelling Society and the Institution of Civil Engineers (Thomas Telford Publishing), 2005
- Joint Code of Practice for Risk Management of Tunnel Works, prepared by the International Tunnelling Insurance Group, 2012 (supercedes BTS/API JCoP, 2003)

3a) Typical ground information required for design and costing

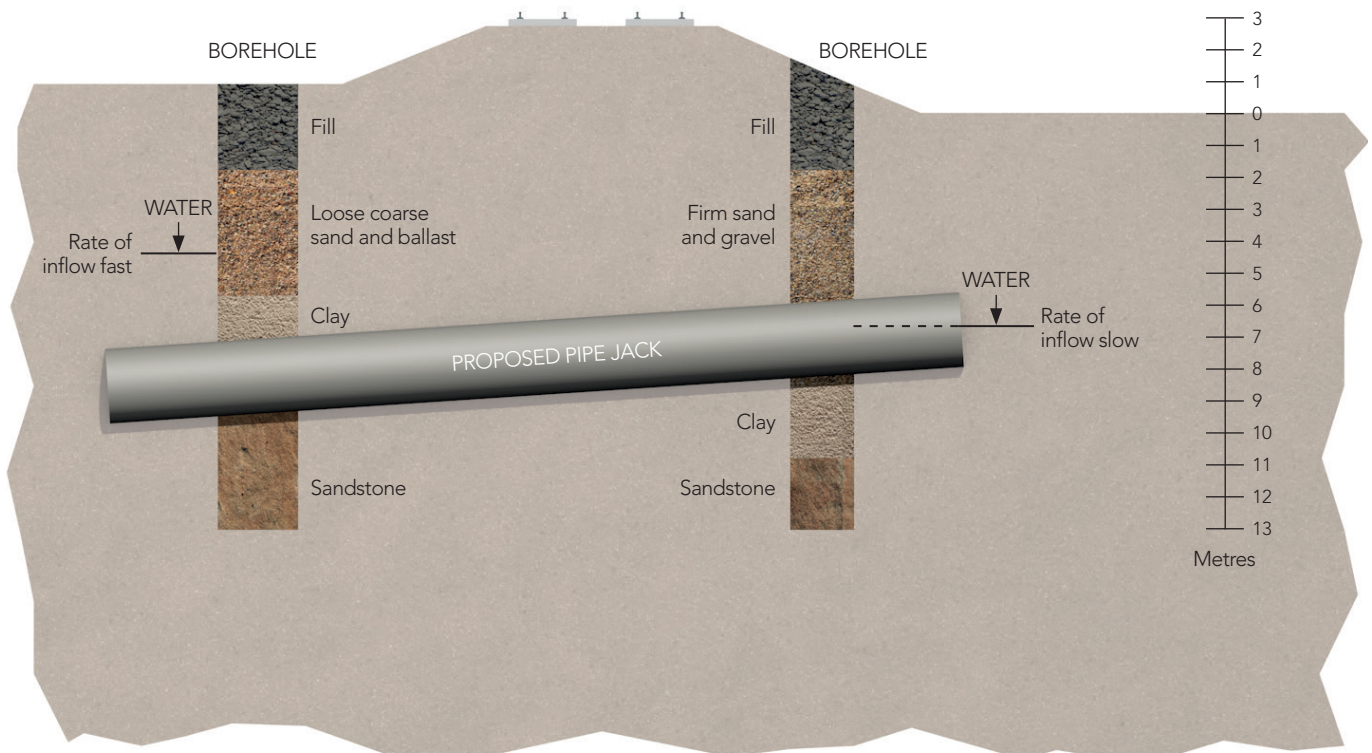

DESK STUDY

For all schemes a desk study should be carried out, assessing the available literature, maps, aerial photographs, utility plans and existing site investigations. The desk study is essential to help understand the broader geological and geotechnical issues, and should be used to determine the scope of any intrusive investigations.



FIELD STUDY

The field exploratory techniques selected should be appropriate to the type of ground and the planned depth of tunnelling. Geo-physical testing, trial pitting, static cone penetration testing and percussive or rotary-drilled boreholes may be used where appropriate. The laboratory testing programme should include tests relevant to the ground conditions and the tunnelling techniques likely to be employed. Table 3b suggests parameters to be considered in relation to each soil type.

3b) Parameters to be considered in relation to each soil type

BOREHOLE POSITIONS

In no circumstances should boreholes be sunk on the line of the tunnel.

Exploratory hole positions should be chosen to provide information on the nature of the ground that will be encountered by the tunnel.

All boreholes should be properly backfilled and sealed. Piezometers should be installed where recommended.

Boreholes should always extend to the tunnel horizon and sufficiently far below the invert level to identify changes in the strata below that could affect the tunnel's construction. Boreholes should be sunk adjacent to shaft locations.

Additional boreholes should be considered to identify the location of significant changes in geology or to resolve other geotechnical uncertainties.

INFORMATION PROVISION

All historical and site investigation information should be provided to the pipe jacking contractor in AGS Format* to enable an accurate assessment of the techniques required to execute the work. If the route of the tunnel is varied after the completion of the site investigation, then the need for further boreholes must be reviewed to ensure that the information provided is still relevant to the revised route. Additional information may also be required as a result of the findings from the initial investigation.

** AGS Format is the standard electronic format for the transfer of geotechnical and geoenvironmental data as recommended by the Association of Geotechnical and Geoenvironmental Specialists.*

| TEST | Non-cohesive | Cohesive | Mixed Soils | Fill Material | Rock |
|--|--------------|----------|-------------|---------------|------|
| Unit weight and moisture content | ● | ● | ● | ● | ● |
| Angle of friction | ● | | ● | ● | |
| Particle size distribution | ● | ● | ● | ● | |
| Abrasivity | ● | ● | ● | ● | ● |
| Cohesion | | ● | ● | ● | |
| Types and proportions of minerals | ● | ● | ● | ● | ● |
| Standard penetration tests | ● | ● | ● | ● | |
| Permeability and nature of ground water flows (seasonal/tidal changes) | ● | | ● | ● | ● |
| Toxic/hazardous constituents in the ground/groundwater | ● | ● | ● | ● | ● |
| Frequency and physical properties of boulders, cobbles or flints | ● | ● | ● | ● | ● |
| Pump down tests | ● | | ● | ● | ● |
| Presence of gases | | | | ● | ● |
| Compressive strength | | | | | ● |
| Rock quality designation (RQD) | | | | | ● |
| Core logging (TCR, SCR, FI) | | | | | ● |
| Tensile strength | | | | | ● |
| Specific energy (excavatability) | | | | | ● |
| Slake durability | | | | | ● |
| Geological description | ● | ● | ● | | ● |
| Plasticity indices (SL, PL, PI) | | ● | ● | | |
| Disaggregation mixing test* | | ● | ● | | |
| RF (x-ray fluorescence) mixing test | | ● | ● | | |

*See N. S. Phillips 2016 on www.pipejacking.org/research

UNSTABLE GROUND CONDITIONS

Tunnelling methods depend on the stability of the ground. Where unstable conditions are likely to be met, the face of the tunnel must be controlled to prevent ground loss, and to enable excavation to take place safely. A controlled face can be achieved by using suitable tunnelling methods such as full face earth pressure balancing machines, or slurry/soft ground TBMs.

Alternatively a stable face when pipe jacking can be achieved using the following geotechnical processes:

- Dewatering by well points or deep wells
- Stabilisation by grouting with cement, cement/bentonite, or chemicals
- In extreme cases, ground freezing

The choice of process is a function of the nature of the ground, the water content, and in particular the particle size analysis. The table below gives an indication of the process applicable to various conditions, but because of the specialist nature of such activity, detailed advice should be sought from a geotechnical engineer.

3c) Face support and ground treatment methods for varying ground conditions

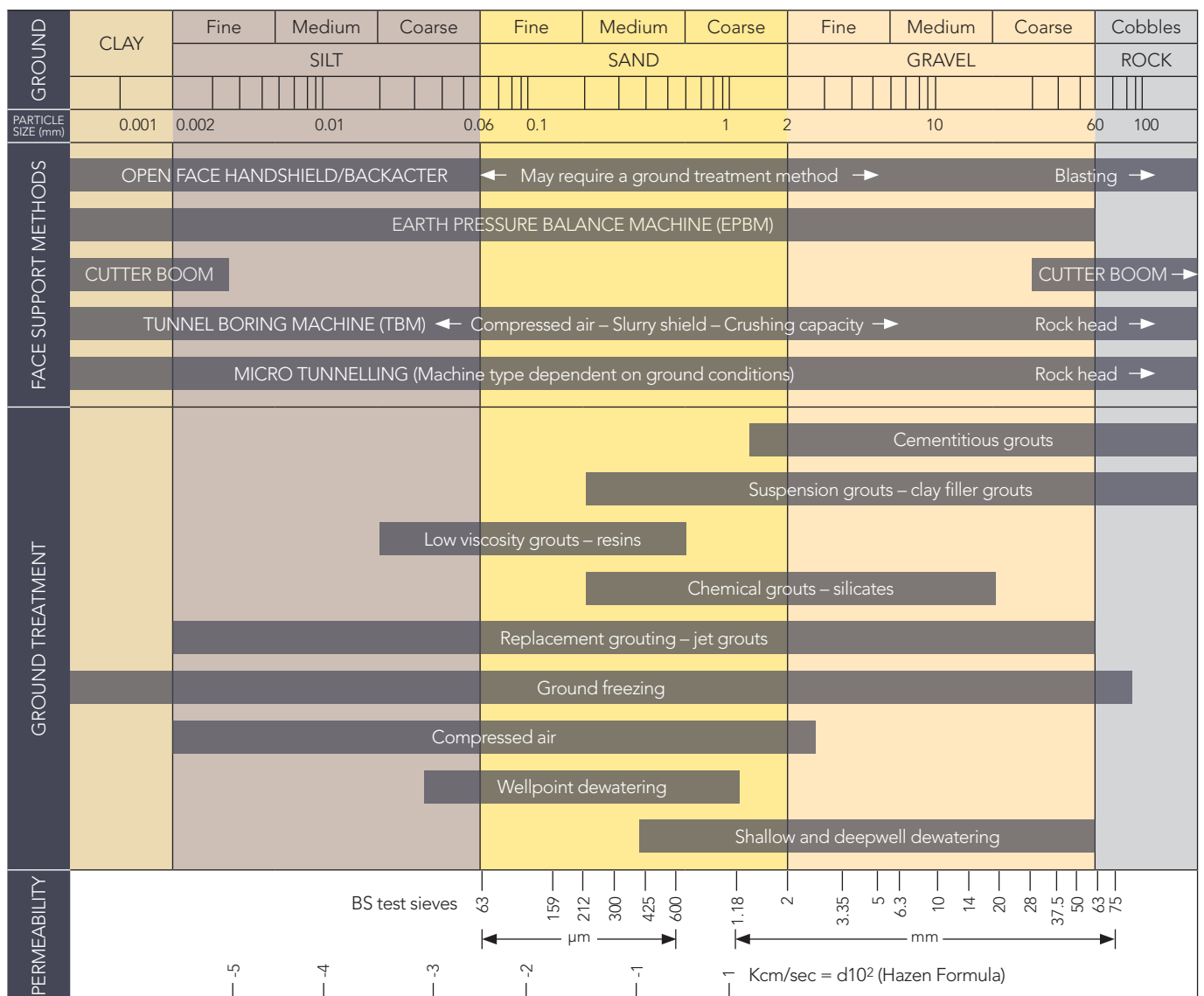

Note: Whilst open face handshield and compressed air are referred to above, these are only used in special circumstances. Reference The Work in Compressed Air Regulations 1996 and British Tunnelling Society (BTS) Guidance on the Work in Compressed Air Regulations 1996.

4 Design and construction methods

Prior to embarking on a detailed construction design and method analysis, the project engineer will generally have ascertained the basic design parameters to meet the requirements of the scheme.

For a sewerage system these are likely to include:

- Hydraulic requirements
- Structural integrity
- Drive lengths and alignment
- Manhole requirements
- Depth
- Gradient

Following an assessment of engineering, environmental and cost parameters, pipe jack excavation method and shaft construction will also be governed by a number of factors which include:

- Ground conditions
- Details of existing services and underground structures
- Location of manholes and working areas
- Lengths required
- Diameters of pipeline
- Economics

Ground conditions will play a major role in determining the type of shaft to be constructed, the pipe jack excavation method and any ground support systems to be used.

Each of these may have limitations in terms of either the diameter or length of drive. The interface between these variables, together with physical considerations, such as the location of manholes and the size of working areas, will provide an optimum solution or range of solutions which can then be appraised on the basis of cost and value engineering.

When considering the use of pipe jacking as an alternative to open cut, an assessment of the advantage of realignment should be made. This may shorten the overall length of the pipeline.





WORKING SHAFTS

A range of working shaft construction methods can be used for pipe jacking operations, including:

- Segmental lining
- Pre-cast or cast insitu caissons
- Sheet piling or secant piling
- Shallow trench sheeted or timber supported excavation
- Battered excavation
- Ground anchorages

In certain instances, ground treatment or groundwater management methods may be required to enable the construction of the shaft to proceed.

These include:

- Well pointing and deep wells
- Compressed air
- Suspension grouts
- Chemical stabilisation
- Ground freezing

The following tables provide a guide to the most common practice for selecting shafts, but are not exhaustive.



4a) Design of working shafts in dry ground

| DRY GROUND: Dry Cohesive, Dry Non-Cohesive and Dry Mixed and Fill Conditions | | | | |
|--|--------------------|---------------------|--|---|
| Type | Size and shape | Depth | Ground treatment | Remarks |
| Segmental | 2.4m dia and above | Unlimited | Not required | Diameter dependent on pipe jacking method, rig and depth considerations |
| Sheet piled | Any | Generally Up to 15m | Not required | |
| Secant piled | Any | Generally Up to 20m | Not required | Needs large working area |
| Trench sheeted | Any | Up to 6m | Not required | Not recommended |
| Pre-cast caisson | 2.4 to 4m dia | Generally Up to 15m | Not required | Suitable for microtunnelling |
| Cast insitu caisson | Any | Unlimited | Not required | Can be water retaining and flotation resistant |
| Battered excavation | Any | Shallow | Needed if angle of repose of soil exceeded | |
| Ground anchorages | Any | Surface level | Not required | For shallow work only |

4b) Design of working shafts in wet ground

| WET GROUND: Wet Cohesive, Wet Non-Cohesive and Wet Mixed and Fill Conditions | | | | |
|--|--------------------|-----------------------------|---|---|
| Type | Size and shape | Depth | Ground treatment | Remarks |
| Segmental | 2.4m dia and above | Limited by ground treatment | Wet caisson method | Grab excavation below water, generally 50m depth |
| | | | Well pointing | Up to 7 metres depth |
| | | | Deep well dewatering Compressed air Suspension grout Chemical stabilisation Ground freezing | Depth dependant on ground conditions and water level |
| Sheet piled | Any | Generally Up to 15m | Well pointing | Up to 7 metres depth |
| | | | Deep well dewatering | Depth dependent on water table draw down and pile cut-off level |
| Secant piled | Any | Generally Up to 20m | May be required for base stability | Needs large working area |
| Trench sheeted | - | - | - | Not recommended |
| Pre-cast caisson | 2.4 to 4m dia | Generally Up to 15m | May be required for base stability | Suitable for microtunnelling |
| Cast insitu caisson | Any | Generally Up to 15m | May be required for base stability | Self weight can overcome skin friction and flotation |
| Battered excavation | - | - | - | Not applicable |
| Ground anchorages | Any | Surface level | Ground treatment and/or piling may be required to provide jacking reaction | Generally used for drives through embankments |

Notes

- Working shafts are designed to suit ground conditions and their intended use. They can be converted to permanent works, ie segmental or caissons to manholes or piled shafts to manhole rings.
- The type of construction is not generally governed by the ground treatment method, which should be considered as an assistance to the construction method.
- In rock, the shaft design will depend on the characteristics of the material.
- Most shaft construction methods require external concrete collars. Consideration should be given during design to the overall plan area and depth.
- For very deep drives in water bearing ground, consideration should be given to pressure limitations of available equipment.

PIPE JACKING EXCAVATION METHODS

A range of pipe jacking excavation methods are illustrated. In most cases, the choice of method will also depend on the selection of the appropriate ground support technique:

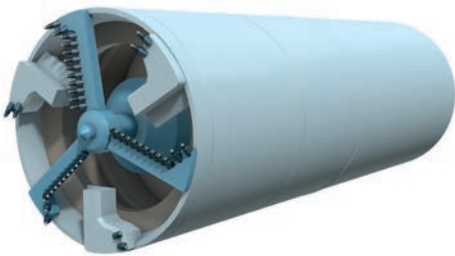

Tunnel boring machine (TBM)
A shield having a rotating cutting head. Various cutting heads are available to suit a broad range of ground conditions.

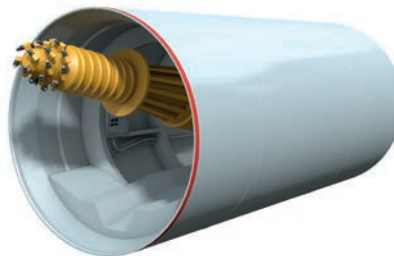

Cutter boom shield
An open face shield in which a cutter boom is mounted for excavation purposes.

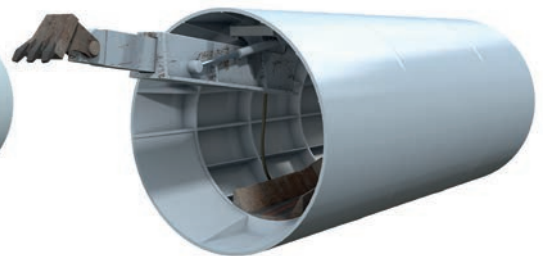

Backacter shield
An open face shield in which a mechanical backacter is mounted for excavation purposes.

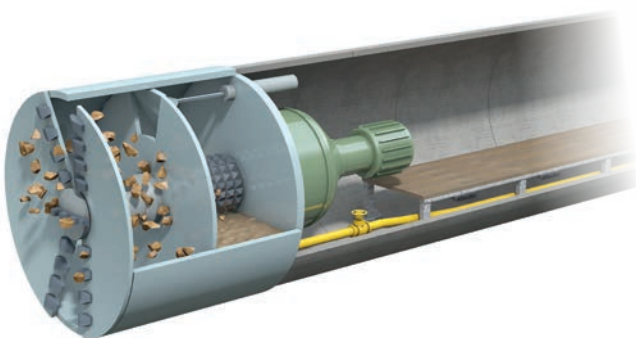

Pressurised slurry machine
'Full-face' tunnel boring machine in which the excavated material is transported from the face suspended in a slurry. Various cutting heads are available to suit a broad range of ground conditions and may incorporate internal crushers to deal with cobbles and small boulders. The pressure of the slurry is used to balance the groundwater and face pressure.

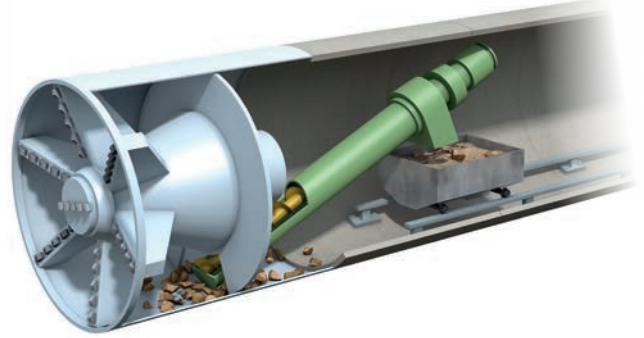

Earth pressure balance machine (EPBM)
A 'full-face' tunnel boring machine in which the excavated material is transported from the face by a balanced screw auger or screw conveyor. The face is supported by excavated material held under pressure behind the cutter head in front of the forward bulkhead. Pressure is controlled by the rate of passage of excavated material through the balanced screw auger or valves on the screw conveyor.

Microtunnelling machines and guided augers

Fully guided machine remotely controlled from the surface, where man entry is generally not required. These microtunnelling machines are typically of two types, pressurised slurry and auger, both having face support capability:

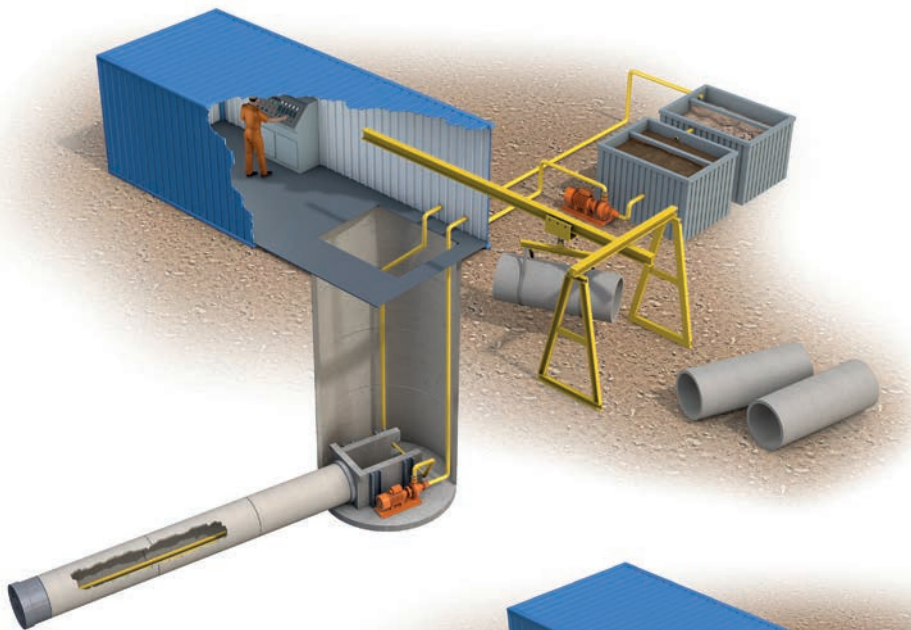

Pressurised slurry

As with the Pressurised slurry TBM, excavated material is transported from the face to the surface suspended in a slurry.

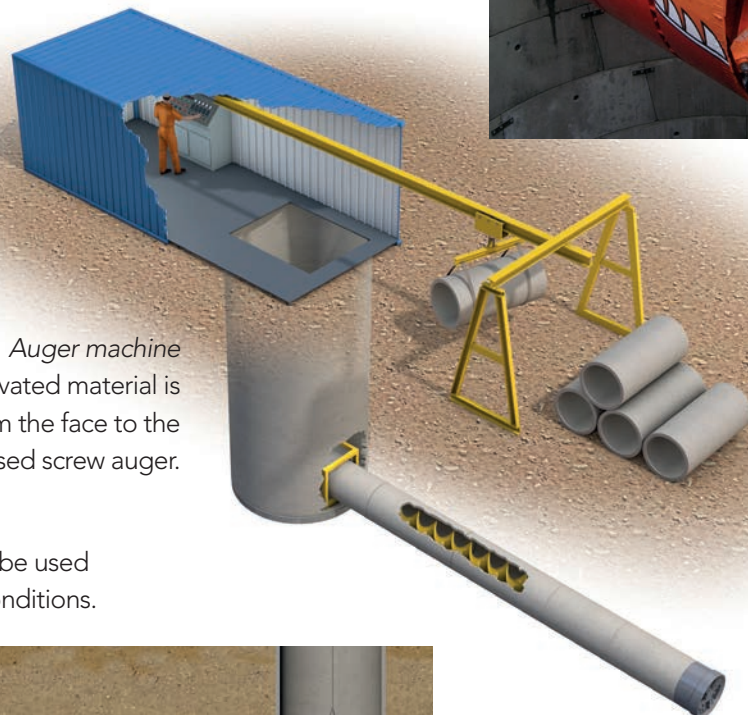

Auger machine

Where excavated material is transported from the face to the drive pit via a cased screw auger.

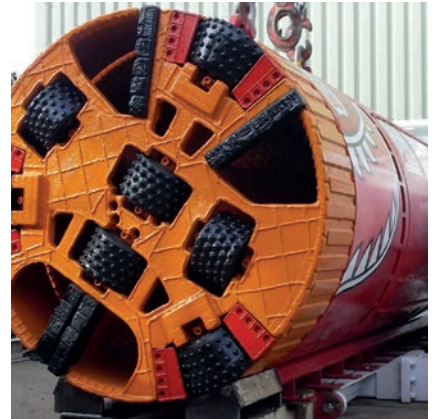

Guided auger boring machines can also be used for pipe installation in suitable ground conditions.

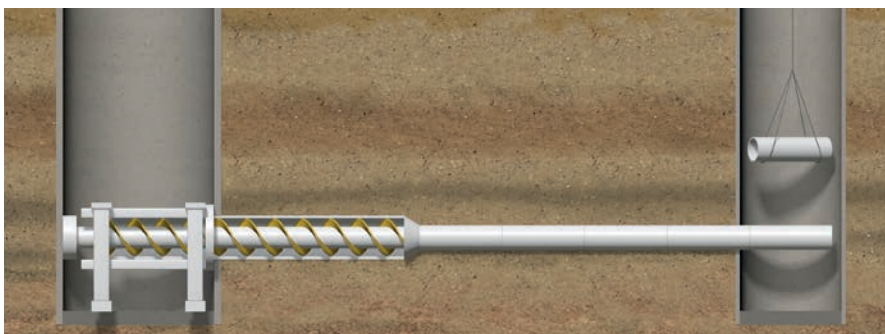

4c) Indicative jacking lengths achievable between shafts for mechanised drives

The information contained in this table is based on PJA members' experience and lengths being achieved internationally for both straight and curved drives. The lengths listed should only be undertaken following extensive risk analysis on individual projects and subject to technical limitations.

| NOMINAL INTERNAL DIAMETER OF TUNNEL LINING IN METRES | | | | | | | | | |
|--|-------|------|------|------|-------|------|------|---------|------|
| Pipe diameter | <0.9m | 0.9m | 1.0m | 1.2m | 1.35m | 1.5m | 1.8m | 1.9/2.1 | 2.4 |
| Length achievable in metres | 150 | 200 | 250 | 450 | 550 | 700 | 900 | 1000 | 2000 |

4d) Curved drives

Standard 2.5 metre long pipes can be jacked up to a 200 metre radius and shorter pipes to tighter curves. Manufacturers' joint deflection guidelines must not be exceeded and special pipes and sealing mechanisms may need to be considered. Load transfer through the joints and the ability of the tunnel shield to be steered to the curve required are key design considerations.

4e) Pipe jacking excavation methods for dry and wet ground

| EXCAVATION METHOD | PIPELINE INTERNAL DIAMETER | DRY GROUND (Dry cohesive, dry non-cohesive and dry mixed and fill conditions) | | WET GROUND (Wet cohesive, wet non-cohesive and wet mixed and fill conditions) | |
|--------------------------------|----------------------------|--|--|--|---|
| | | FACE SUPPORT | REMARKS | FACE SUPPORT | REMARKS |
| Open face TBM | 1200-3000 | None | Only applicable to stable face conditions, including rock | Chemical stabilisation Suspension grouts Well points Deep wells | Only applicable to stable face conditions |
| Cutter boom shield | | | Only applicable to strong cohesive soils and soft rock | | - |
| Backacter shield | | | Only applicable to stable face conditions | | - |
| Pressurised slurry machine | 1400-3000 | In-built method | - | In-built method | - |
| Earth pressure balance machine | | | - | Additives in certain ground conditions | Limited to water pressure head |
| Microtunnelling | | | 150-1000 | - | Dependant on type of machine |
| Open hand shield | 1200-3000 | Consider face boards and soil trays | Limited by safety considerations and exposure to HAVS (see note b) | Chemical stabilisation Suspension grouts Well points Deep wells | Subject to ground conditions. Limited by safety considerations and exposure to HAVS (see note b) |

Notes

- Reference should be made to Tunnelling and pipe jacking guidance for designers published by the Health and Safety Executive, Pipe Jacking Association and the British Tunnelling Society available from www.pipejacking.org. Some of the lengths outlined above are in excess of those outlined in this document but are considered by the PJA as acceptable as long as foreseeable hazards to include access and egress of operatives, where they are working within the tunnel, and any other risks are adequately considered.
- Hand excavation is only carried out on short sections where no alternative construction method is available.
For further information see Guidance on the design of hand excavated pipe jacks available from www.pipejacking.org.uk.
- When selecting mechanical excavation methods the drive lengths may be influenced by the need for interjacks, lubrication methods and other economics.
- When selecting a 'full face' machine, consideration should be given to the ability of the machine to deal with cobbles, boulders, or any other obstructions.
- Disposal of spoil from slurry machines may require special handling and disposal facilities at working shafts.
- Rock can be excavated using a cutter boom shield, a full face TBM, a pressurised slurry machine or a microtunnelling machine.
- Consideration must be given to ground stability around the pipe jack entry and exit eyes in shafts. This can be by a number of methods, for example, the use of gland assemblies, pressure grouting, or localised dewatering.

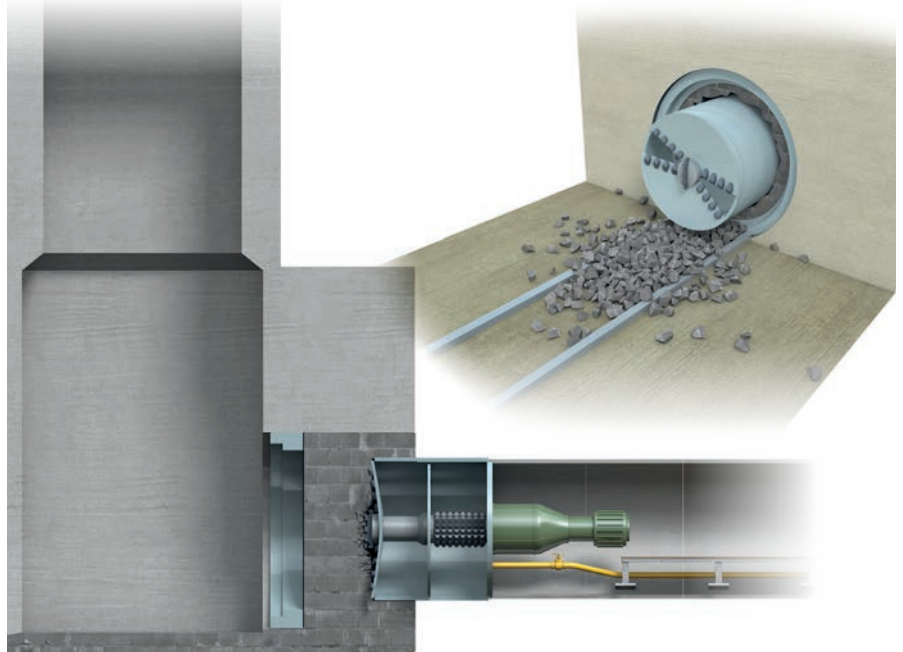

Typical pipe jacking eyes (see note (g) on page 18 opposite)

SLURRY AND EPB TUNNELLING

Where a pipejack or microtunnel is to be installed using a pressurised slurry system the design control and management of the slurry and the separation equipment that removes the excavated soils from the slurry is critical to the success of the pipejacking or microtunnelling operation.

A slurry system uses water based fluid (slurry) to transport excavated soils from the tunnelling machine to the surface where the excavated soil is removed from the slurry enabling the re-use of the slurry for further excavation.

There are a number of factors that guide the formulation of the slurry. The main consideration is the geology through which the pipejack or microtunnel is to be constructed but also the length and depth of the drive is important.

The EPBM excavation process is similar to that of an STM in that the arisings enter the plenum chamber through the cutterhead.

Ground and groundwater pressure at the tunnel face are balanced by compressing these arisings in the plenum. The forward thrust of the shield develops pressure in the plenum whilst at the same time mixing and plasticising the soil. When the face pressure is balanced the soil is evacuated via a screw conveyor. As the soil travels along the auger the pressure dissipates, allowing it to discharge at the end of the screw at atmospheric pressure.

EPBMs work best in cohesive soils. Where sand and gravels are encountered in a mixed face, these may be conditioned by injecting additives such as bentonite, water or polymers into the plenum and/or the screw to plasticise them and render them suitable for generating a plug of pressurised soil.

The rate of excavation of the pressurised soil through the screw conveyor is balanced to the rate at which excavated soil is entering the plenum, thereby facilitating the maintenance of a plug of pressurised soil in the plenum, which balances and stabilises the face pressure.

SAFETY

As stated in Section 2, pipe jacking is an inherently safer method of working than open trench construction or segmental tunnelling.

With the advent of the Construction Design and Management (CDM) Regulations clients and designers have significant responsibilities imposed on them and may find that risks may be eliminated or mitigated by opting for the pipejacking or microtunnelling method of construction.



Typical slurry separation plant

5 Pipe jacking pipes

A range of materials are used as pipe jacking linings including concrete, grp, clay and steel.

The selection of linings is generally dependent on the application and in some cases ground conditions. Where inherent strength and accuracy is required, for example in gravity drainage in urban locations, factory made concrete, or vitrified clay in the smaller diameters, is usually preferred. Grp pipes, specialist internal linings and high pressure joints are available to meet specific site or project requirements. Steel pipes are also used, either as a primary lining, where appropriate, or as a sleeve for the installation of a range of utilities, gas, water and electricity or other cabling applications.

Standard diameters for concrete pipes are in the range 450mm to 2400mm although larger diameters can be manufactured to meet specific requirement. Planning for safe handling and storage of pipes should be part of the scheme design. Clay pipes are commonly available in the range 150mm to 700mm. Steel pipes can be manufactured to meet project requirements.

Advice on jointing techniques, site handling, and joint packings should be obtained from the manufacturer.

CONCRETE PIPES

In the UK concrete jacking pipes are manufactured to comply with the requirements of BS EN 1916 and BS 5911-1. Products should be manufactured under a third party certified quality management system complying with ISO 9001 and the pipes should be kitemarked.

Concrete pipes are designed to meet the load class defined in the product standard, although higher strength classes can be manufactured where circumstances demand. The pipes and joints are designed to withstand jacking loads applied during installation, and information on jacking strengths should be obtained from the manufacturer.

Pipes are normally supplied in lengths of between 1.2 and 2.5 m and feature a joint incorporating an elastomeric gasket to provide a watertight connection. The joint design includes including capacity for joint deflection and draw as defined in the product standard. Secondary seals may be incorporated into the joint if required.

Concrete pressure pipes can also be supplied.



Typical flexible joints

Specially rebated leading pipes can be produced for insertion into the jacking shield. Similarly, special rebated pipes are produced for the trailing pipes at intermediate jacking stations (interjacks). Leading pipes at interjack stations can be supplied to fit directly to an interjack shield or may be produced with an integral interjack shield.

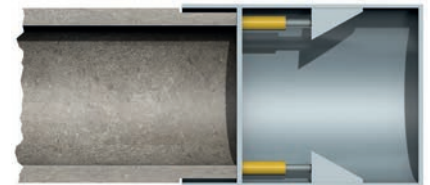

Rebated lead pipes

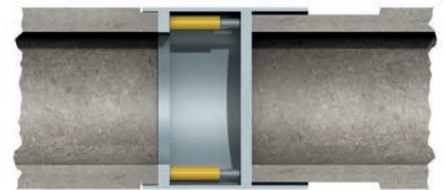

Interjack pipes

Packers must be incorporated into each joint in order to distribute the jacking pressure and avoid point loads to prevent damage to the ends of the pipes during the jacking process. Medium density fibreboard (MDF) has been found to be the best material from which to fabricate joint packers. Research carried out by the Pipe Jacking Association has shown that MDF is the most suitable under repeated loading of the timber based materials, having excellent recovery characteristics. The packers should not extend over the full joint width, a small gap being left to the inside surface of the pipes to prevent localised spalling.



Steel cage used in concrete pipes



Concrete pipes

CLAY PIPES

Vitrified Clay pipes for microtunnelling and pipe jacking are manufactured to achieve high axial strength. They will withstand the jacking forces used during installation, and the ground loads imposed during their working life. Pipes should be manufactured in accordance with BS EN295-7 and BS EN12889: 2000. They should be obtained from a certified manufacturer, such that they will be supplied from a factory which is quality assured to ISO 9001, and the pipes should be kitemarked.

Benefits of clay pipe include chemical resistance and longevity.

The pipe ends are machined to produce an accurate joint profile. Collars are typically fabricated from Stainless Steel. The joint will incorporate a rubber seal, most likely EPDM (Ethylene Propylene Diene Monomer). Pipe lengths are usually in the 1.0-2.0 metre range for the more common smaller diameters.



Clay pipe joint detail

As with concrete jacking pipes packers are used to prevent damage to the pipe ends during the jacking process.



Clay pipes

STEEL PIPES

Steel pipes of varying lengths are used as sleeves for the installation of gas, oil and water pipelines where fine tolerances in line and level are not usually required. Factors such as welding time and pit size should be considered when determining the length of each individual pipe.

SECONDARY LININGS / REINVERTING

There may be certain drives where because of the nature of the ground, the required length of drive, or end use, it is considered desirable to jack a pipe of larger diameter than required as the primary lining or sleeve. The finished diameter is then achieved by either reinverting or by installing smaller diameter secondary pipes.



Typical reinverting and secondary lining detail

Secondary inverts and pipes can be constructed in a range of materials such as concrete, steel, upvc, or vitrified clay, depending on the material to be conveyed. Secondary pipe linings can be laid in the invert or supported on steel centralisers. Where required the annular space can be filled with a cementitious grout.

6 Jacking lengths, loads and tolerances

JACKING LENGTHS

Refer to table 4c) and note a) on page 18. The length over which a pipejack can be installed is dependent upon a number of interrelated and variable factors: the stability and friction characteristics of the geology to be tunnelled through, the self-weight and strength of the pipes, the diameter of pipe, the type of excavation method, and the available jacking reaction. The major constraint will be the nature of the ground and the ground water characteristics. However, the distance that can be achieved is optimised by the use of a range of techniques.



INTERMEDIATE JACKING STATIONS (INTERJACKS)

In order to redistribute the total required jacking force on the pipeline, intermediate jacking stations are frequently used between the launch pit jacking rig and the tunnelling machine. A special twin pipe set incorporating an increased length steel collar which slides over a corresponding length spigot detail is introduced into the pipeline. Hydraulic jacks are placed between the two opposing pipes such that when activated they open the gap between the leading and trailing pipes. The interjack station is then moved forward with the pipeline in the normal way until it becomes necessary to supplement the jacking forces available from the shaft. On reaching the design value or when the available thrust force is insufficient to move the pipeline forward, then the pipes behind the intermediate jacking station are held stressed back to the thrust wall in the launch pit. The jacks in the intermediate jacking station are then opened, thus advancing the forward section of the pipeline.

At completion of the stroke of the inter-jacks, the main jacks in the thrust pit are actuated, advancing the rear of the pipeline to its original position relative to the leading pipes, and thereby closing the intermediate station jacks. The sequence is then repeated for the duration of the pipe-jack and, on completion, the jacks and fittings are removed and the inter jack closed up.

Interjack stations are not only used to increase the jacking lengths achievable, but also to reduce the loads that are transmitted to the shaft structure. This is useful where ground conditions at the drive shaft are poor or of low inherent strength.



Intermediate jacking stations

LUBRICATION

The pipe jack shield or machine is designed to produce a small overbreak to the external diameter of the pipeline. By injecting a lubricant, for example bentonite, into this annulus the pipeline can, in theory, be jacked freely through a fluid medium.

In practice, however, fluid losses may occur into the surrounding ground. Providing these can be controlled, the technique results in considerable reductions in jacking forces and therefore longer jacking lengths.



Typical lubrication arrangement

JACKING LOADS

Loads required to jack the pipeline forward are mainly a function of frictional forces built up around the pipeline. These forces depend on the type of ground and, in particular, its arching characteristics, friction angle, the depth of overburden, the depth of the ground water and any surcharge load, the length and diameter of the pipe being jacked and the time taken for the operation.

Whilst it is difficult to accurately assess these forces using soil mechanics theory, pipe jacking contractors have, after years of experience, derived empirical values. As a guide, frictional forces fall between 0.5 and 2.5 tonnes per square metre of external circumferential area. The use of sophisticated lubricant injection techniques can reduce frictional forces to as little as 0.1 tonnes per square metre.

Frictional forces on the pipeline may be reduced by applying a suitable lubricant, under a nominal pressure above that of the ground water pressure present. If high frictional resistance is anticipated, it is recommended that intermediate jacking stations are placed at regular intervals in the pipeline.

These jacking loads must be resisted by a jacking reaction built up within the thrust shaft. This is normally achieved by the construction of a thrust wall at the back of the thrust pit designed to withstand the anticipated jacking load and to suitably transfer such loading through the shaft structure to the surrounding ground.

JACKING TOLERANCES

In stable, self-supporting, homogenous ground, the typical tolerance for pipe installation is $\pm 50\text{mm}$ of a true line and level at any point in the drive. However, in some ground conditions, particularly unstable ground or where obstructions are present, these tolerances may not be readily attainable. In such circumstances where this tolerance or a finer one must be achieved, larger pipe sizes can be considered. Adjustments to line and level should be gradual to ensure that the pipe manufacturer's stated permitted angular deflection is not exceeded at any individual joint.

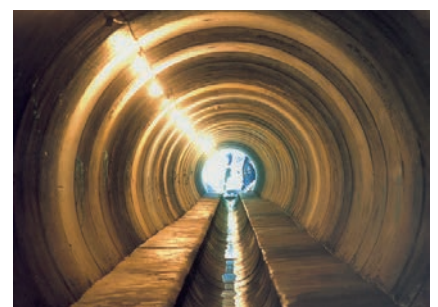

Published by: Pipe Jacking Association
www.pipejacking.org

